

## INSTRUCTION MANUAL - TM 12 SAFETY TRIPOD

### DESCRIPTION

TM 12 safety tripod is a component of personal protective equipment against falls from height. TM 12 tripod is portable, class B temporary anchor device and is used to protect employees (using Trolleys A or B, Main Tripod or Beam Attachment Points) working in drainage wells, reservoirs, wells, silos, etc. during lifting loads (using Trolleys A or B or Main Tripod). For personal protection tripod must be used in conjunction with fall arrest equipment. Tripod provides protection for two persons simultaneously. The device complies with EN 795 class B.

Legs made of duraluminium profiles with rounded edges. They consist two sections. The telescopic construction of the legs allows the user to adjust their length. To adjust the legs' length locking pins are used. The legs of the tripod are equipped with self-aligning steel feet with rubber pads. Total working load limit (WLL) is 1000kg. Total weight of the tripod: 72kg. Tripod working dimensions are shown below (legs fully extended...retracted) in cm.

Safety tripod TM12 consist of three separate elements: Main tripod (with three legs for lifting loads and personal protective use), Support Tripod (with two legs) and Beam with trolleys (for lifting loads and personal protective use).

5 attachment points (EN 795 class B):

- (1) - Main Tripod Attachment Point,
- (2) - Trolley A,
- (3) - Trolley B,
- (4)(5) - Beam Attachment Points.

### READ CAREFULLY BEFORE USE THE EQUIPMENT

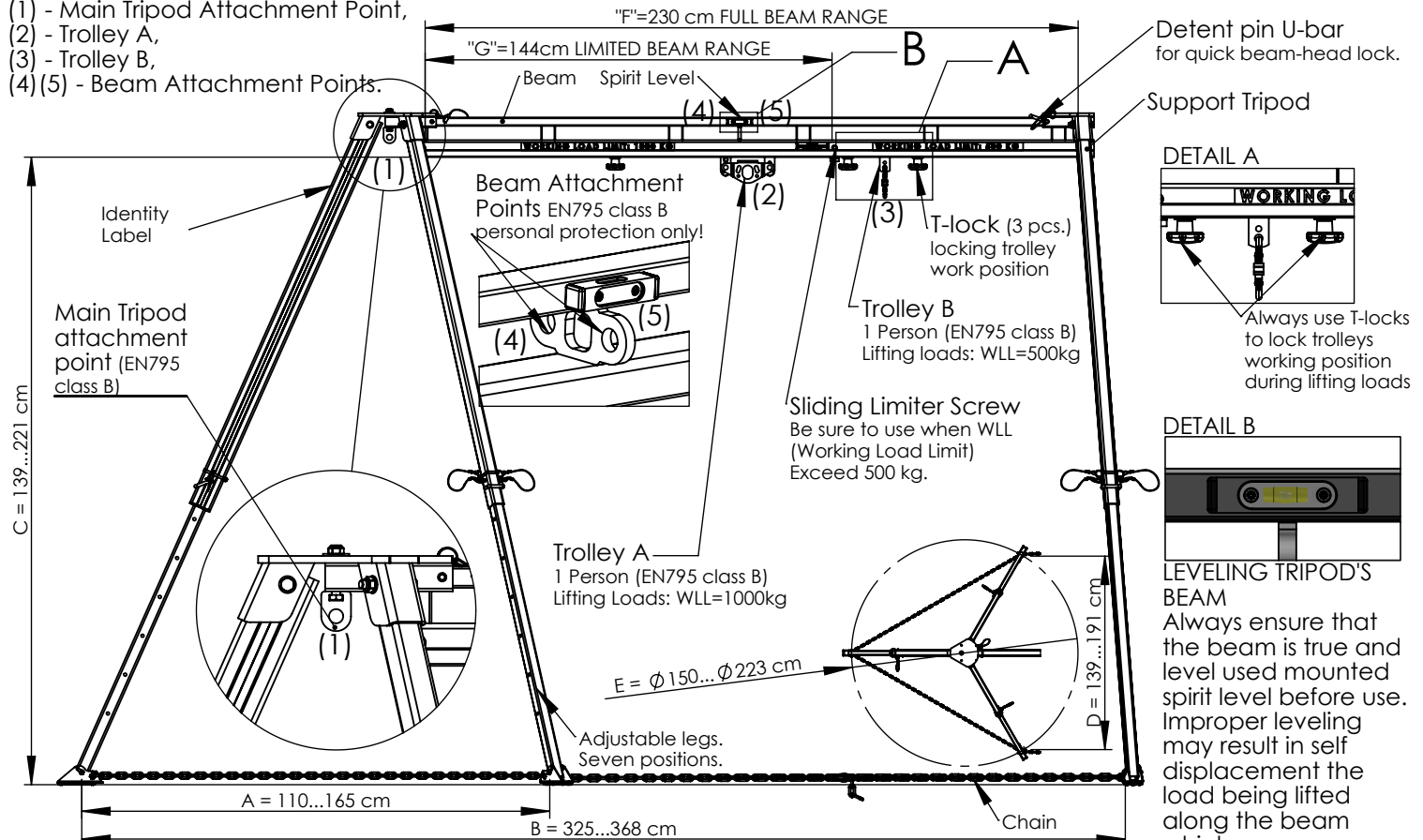

### ! PRECAUTIONS !

- ! While working, pay attention to the chain, which fastens the tripod legs, as it can cause accidental tripping of the worker.
- ! The tripod must never be used without the leg chain in place.
- ! Avoid working where the user may swing and hit an object or where lines may cross or tangle with that of another worker in the area.
- ! Fall arrest and rescue systems used with this tripod must meet applicable EN standard requirements: (EN 795 - for anchor devices; EN 362 - for connectors; EN361 - for full body harnesses; EN 360 - for retractable type fall arresters; EN 1496 - for rescue lifting devices; EN1497 - for rescue harnesses; EN 341 - for descender devices.
- ! During installing Lifting Device RUP 503 Grip Locking Pin must be embedded in locking hole. Only then Grip can be safely clamped on the Outside Leg.
- ! ALWAYS USE T-lock's to maintain Trolleys required position.
- ! Total load can not exceed 1000 kg!
- ! DO NOT use TM 12 safety tripod for more than two people simultaneously!
- ! DO NOT connect 2 people to both Trolleys at the same time!
- ! DO NOT connect 2 people to both Beam Attachment Points at the same time!
- ! ALWAYS USE Sliding Limiter Screw when Trolley A is used to lifting loads (1000kg)!
- ! DO NOT use Beam Attachment Points for lifting loads!

### CONTENT OF THE IDENTITY LABEL

- a) Device type.
- b) Model symbol.
- c) Reference number.
- d) Number/year/class of the European standard.
- e) CE marking and number of a notified body controlling manufacturing of the equipment.
- f) Month and year of manufacture.
- g) Serial number of the tripod.
- h) Caution: read the manual.
- i) Marking of the manufacturer or distributor of the tripod.

e	d	b	a	c	h	f	i	g
<b>CE 0082</b>	EN 795:1996/B + A1:2000	<b>SAFETY TRIPOD</b>	<b>TM-12</b>	Ref.: AT 014	Date of manufacture: 01. 2012	Serial number: <b>0000000</b>	<b>Canasafe™</b>	

## INSTALLING A MAIN TRIPOD ONLY (Figure 1)

1. Place the main tripod in an upright position on a flat, stable and hard surface.
2. Make sure the feet are on firm ground and can support the load.
3. Pull out the tripod legs to the desired length and lock with the locking pin.
4. Make sure the locking pins are properly secured. The end of the locking pin must protrude above the surface of the tripod legs.
5. Adjust the length of the legs so that the head is located in the horizontal plane.
6. The legs must always have the same length.
7. The tripod should be positioned over opening so working line will be located approximately in the center of the opening.
8. Secure the tripod legs with the chain against the accidental sliding open. The ends of the chain must be fastened with a snap hook. The chain should be tight between the legs of the tripod. Remove excess slack of the chain.
9. To collapse main tripod pull leg down and swing the leg.

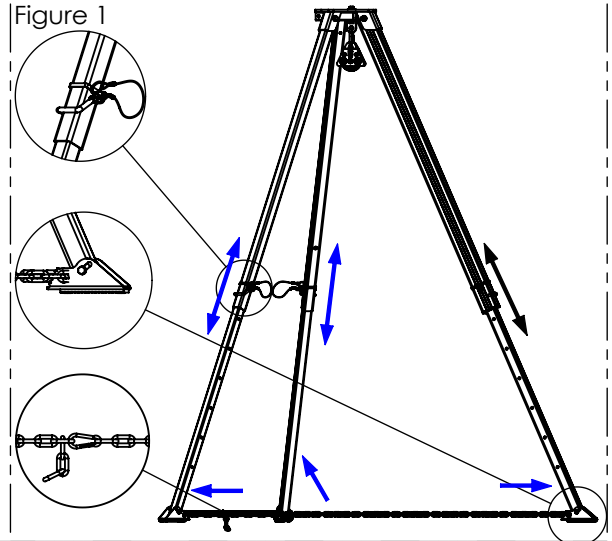

## INSTALLING TRIPOD FULL SET

1. Set the main tripod according to above instructions without chain. Legs should be pulled out and lock with the locking pin in the lowest possible position (Figure 2).
2. Place the support tripod on a flat, stable and hard surface. Legs should be pulled out and lock with the locking pin in the lowest possible position. Place the end of the beam in the support tripod's clamping and lock with the locking pin (Figure 3).
3. Raise chamfered end of the beam and place in the main tripod's clamping and lock with the locking pin. (Figure 2 and Figure 3).
4. Connect pulley to the main tripod attachment point. Be sure that nut in AZ 090 connector is fully tightened (Figure 4).
5. Connect pulley to the load trolley support anchor point. Be sure that nut in AZ 090 connector is fully tightened (Figure 4).
6. Make sure the feet are on firm ground and can support the load.
7. Firstly pull out the main tripod legs to the desired length and lock with the locking pin. Lastly pull out the support tripod legs to the same length as main tripod legs. All the legs must always have the same length. Make sure the locking pins are properly secured. The end of the locking pin must protrude above the surface of the tripod legs.
8. The tripod should be positioned over opening so working line will be located approximately in the center of the opening.
9. Secure the tripod legs with the chain against the accidental sliding open. The ends of the chain must be fastened with a snap hook. The chain should be tight between the legs of the tripod. Remove excess slack of the chain.
10. To collapse tripod pull legs down and swing leg in.

Figure 2

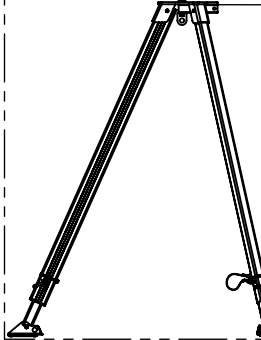

Figure 3

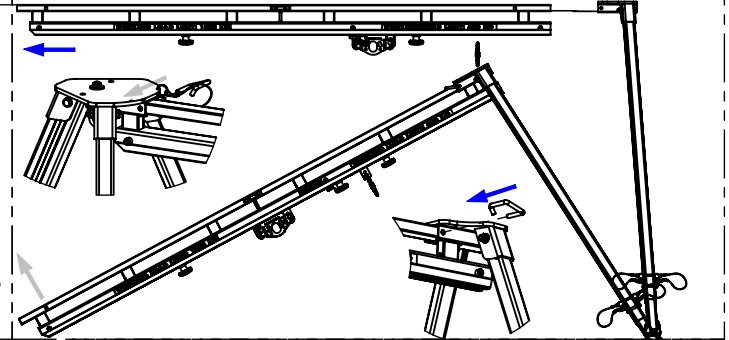
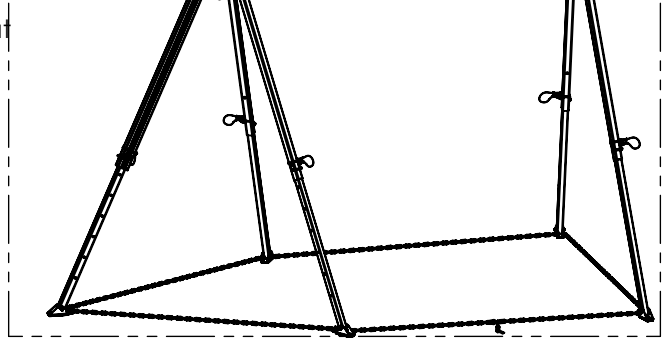

Figure 4

Main Tripod Pulley



## INSTALLING RUP 503 LIFTING DEVICE ON TM 12 REINFORCED LEG

The tripod can be used with RUP 503 rescue lifting device conforming EN 1496. The grip of the RUP 503 should be fastened on the locking hole situated on the top wall of the reinforced leg profile. The cable should be guided on a main tripod pulley. For proper and safe installation and use of the RUP 503 follow its instruction manual.

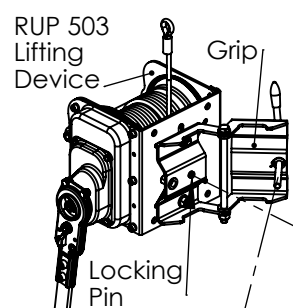

Grease with small amount of constant lubricator Lever thread before install.

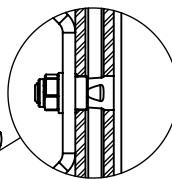
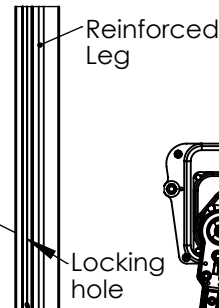

Lifting device PROPERLY mounted on the reinforced leg - locking pin in the socket.

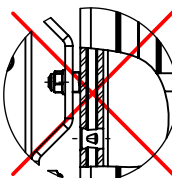

Lifting device IMPROPERLY mounted on the outside leg - locking pin out of the socket, based on the leg.

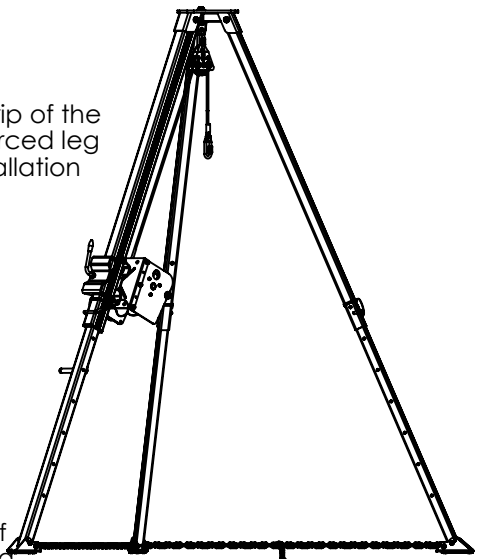

AVAILABLE ATTACHMENT POINTS: (1) Main Tripod Attachment Point (EN795 class B) (2) Trolley A (EN 795 class B) (3) Trolley B (EN 795 class B) (4) (5) Beam attachment Points

**POSSIBLE USAGE VARIANTS:**

**1. MAIN TRIPOD ONLY WITH RUP503 (WITHOUT BEAM AND SUPPORT TROLLEY)**

Max. 1 Person Protection (140kg) OR lifting loads (WLL up to 1000kg) when using additional lifting device for loads

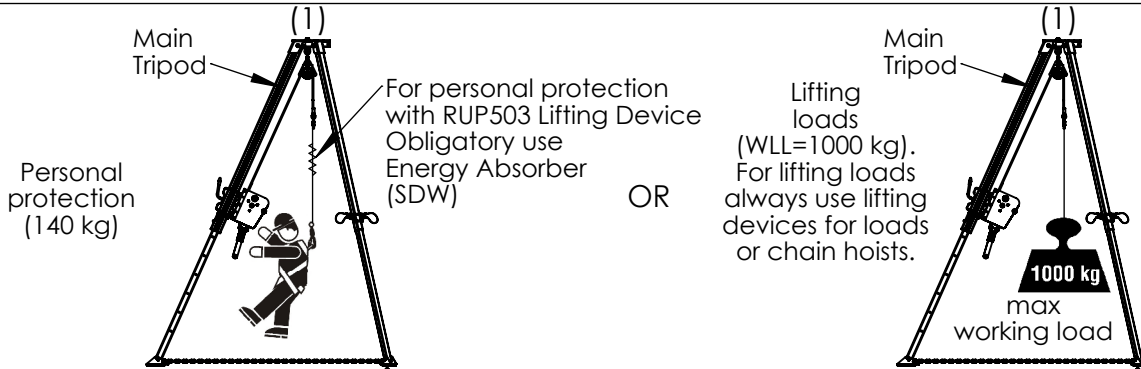

**2. FULL TRIPOD SET**

Max. 2 People Protection AND lifting loads (WLL up to 1000kg)

Possible attachment points usage:

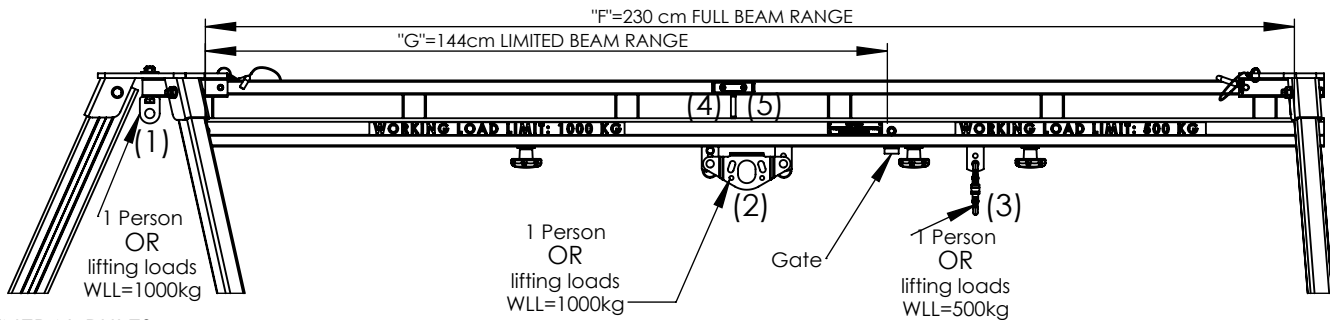

**GENERAL RULES:**

1. Trolley A (for lifting loads up to 1000kg) can be use ONLY on the Limited Beam Range. Trolley A CANNOT pass through Gate.
2. Trolley B (for lifting loads up to 500kg) can be use on the Full Beam Range. Trolley B can pass through Gate.

**RULES FOR PERSONAL PROTECTION:**

1. Attachment points for personal protection: (1), (2), (3), (4), (5).
2. One attachment point can be use ONLY for one person.
3. Max. 2 people can be attached to the available attachment points at the same time.
3. ONLY one Trolley can be used for personal protection at the same time.
5. ONLY one Beam attachment points can be used for personal protection at the same time.
6. Beam attachment points USE ONLY for personal protective purposes.

**RULES FOR LIFTING LOADS:**

1. Attachment points for lifting loads: (1), (2), (3).
2. Trolley A can be use for lifting loads up to 1000kg.
3. ALWAYS USE Sliding Limiter Screw when Trolley A is used for lifting loads.
4. Trolley B can be use for lifting loads up to 500kg.
5. Main Tripod Attachment Point (1) can be use for lifting loads with lifting device intended for lifting loads (1000kg).
6. Attachment points (1), (2), (3) can be used simultaneously for lifting loads. Total load CANNOT exceed 1000kg.

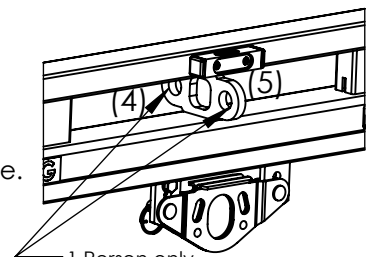

1 Person only  
! DO NOT connect 2 people to these Points at the same time!  
!DO NOT use for lifting loads!

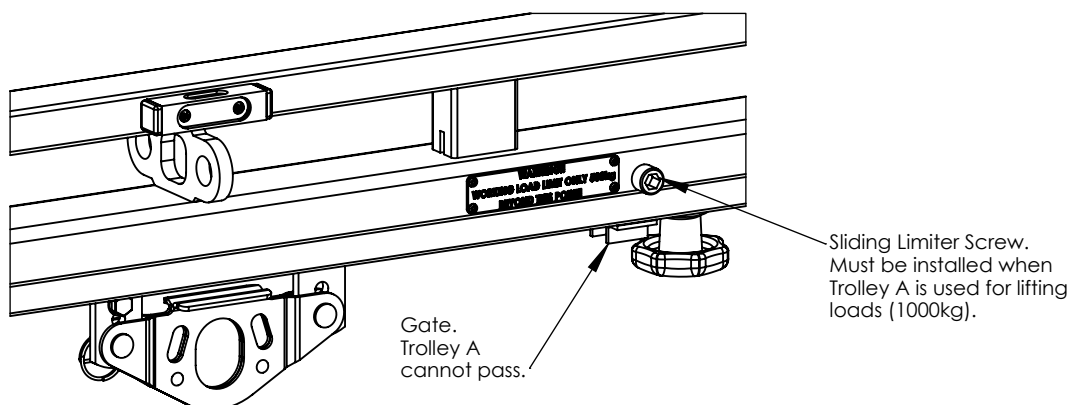

**THE ESSENTIAL PRINCIPLES FOR USERS OF PERSONAL PROTECTIVE EQUIPMENT AGAINST FALLS FROM A HEIGHT**

- personal protective equipment shall only be used by a person trained and competent in its safe use.
  - personal protective equipment must not be used by a person with medical condition that could affect the safety of the equipment user in normal and emergency use.
  - a rescue plan shall be in place to deal with any emergencies that could arise during the work.
  - it is forbidden to make any alterations or additions to the equipment without the manufacturer's prior written consent.
  - any repair shall only be carried out by equipment manufacturer or his certified representative.
  - personal protective equipment shall not be used outside its limitations, or for any purpose other than that for which it is intended.
  - personal protective equipment should be a personal issue item.
  - before use ensure about the compatibility of items equipment assembled into fall arrest system. Periodically check connecting and adjusting of the equipment components to avoid accidental loosening or disconnecting of the components.
  - it is forbidden to use combinations of items of equipment in which the safe function of any one item is affected by or interferes with the safe function of another.
  - before each use of personal protective equipment it is obligatory to carry out a pre-use check of the equipment, to ensure that it is in a serviceable condition and operates correctly before it is used.
  - during pre-use check it is necessary to inspect all elements of the equipment in respect of any damages, excessive wear, corrosion, abrasion, cutting or incorrect acting, especially take into consideration:
    - + in full body harnesses and belts - buckles, adjusting elements, attaching points, webbings, seams, loops;
    - + in energy absorbers - attaching loops, webbing, seams, casing, connectors;
    - + in textile lanyards or lifelines or guidelines - rope, loops, thimbles, connectors, adjusting elements, splices;
    - + in steel lanyards or lifelines or guidelines - cable, wires, clips, ferrules, loops, thimbles, connectors, adjusting elements;
    - + in retractable fall arresters - cable or webbing, retractor and brake proper acting, casing, energy absorber, connector;
    - + in guided type fall arresters - body of the fall arrester, sliding junction, locking gear acting, rivets and screws, connector, energy absorber;
    - + in connectors - main body, rivets, gate, locking gear acting;
    - + in tripods - legs, safety pins, eye bolts, feet, chain, connecting elements.
  - after every 12 months of utilization, personal protective equipment must be withdrawn from use to carry out periodical detailed inspection. The periodic inspection must be carried out by a competent person for periodic inspection. The periodic inspection can be carried out also by the manufacturer or his authorized representative. In case of some types of the complex equipment e.g. some types of retractable fall arresters the annual inspection can be carried out only by the manufacturer or his authorized representative.
  - regular periodic inspections are the essential for equipment maintenance and the safety of the users which depends upon the continued efficiency and durability of the equipment.
  - during periodic inspection it is necessary to check the legibility of the equipment marking.
  - it is essential to the safety of the user that if the product is re-sold outside the original country of destination the reseller shall provide instruction for use, for maintenance, for periodic examination and for repair in language of the country in which the product is to be sold.
  - personal protective equipment must be withdrawn from use immediately when any doubt arise about its condition for safe use and not used again until confirmed in writing by equipment manufacturer or his representative after carried out the detailed inspection.
  - a full body harness (conforming EN 361) is the only acceptable body holding device that can be used in a fall arrest system.
  - in full body harness use only attaching points marked with big letter "A" to attach a fall arrest system.
  - the anchor device or anchor point to the fall arrest system should always be positioned, and the work carried out in such a way, as to minimise both the potential for falls and potential fall distance. The anchor device/point should be placed above the position of the user. The shape and construction of the anchor device/point shall not allowed to self-acting disconnection of the equipment. Minimal static strength of the anchor device/point is 10 kN. It is recommended to use certified and marked structural anchor point complied with EN795.
  - it is obligatory to verify the free space required beneath the user at the workplace before each occasion of use the fall arrest system, so that, in the case of a fall, there will be no collision with the ground or other obstacle in the fall path. The required value of the free space should be taken from instruction manual of used equipment.
  - there are many hazards that may affect the performance of the equipment and corresponding safety precautions that have to be observed during equipment utilization, especially:
    - + trailing or looping of lanyards or lifelines over sharp edges, + any defects like cutting, abrasion, corrosion, + climatic exposure, + pendulum falls, + extremes of temperature, + chemical reagents, + electrical conductivity.
  - personal protective equipment must be transported in the package (e.g.: bag made of moisture-proof textile or foil bag or cases made of steel or plastic) to protect in against damage or moisture.
  - the equipment can be cleaned without causing adverse effect on the materials in the manufacture of the equipment. For textile products use mild detergents for delicate fabrics, wash by hand or in a machine and rinse in water. Plastic parts can be cleaned only with water. When the equipment becomes wet, either from being in use or when due cleaning, it shall be allowed to dry naturally, and shall be kept away from direct heat. In metallic products some mechanic parts (spring, pin, hinge, tec.) can be regularly slightly lubricated to ensure better operation. Other maintenance and cleaning procedures should be adhered to detailed instructions stated in the manual of the equipment.
  - personal protective equipment should be stored loosely packed, in a well-ventilated place, protected from direct light, ultraviolet degradation, damp environment, sharp edges, extreme temperatures and corrosive or aggressive substances.
- WITHDRAWAL FROM USE AFTER ARRESTING A FALL**
- Safety tripod TM12 must be withdrawn from use immediately when it have been used to arrest a fall. After that must be carried out detailed manufacturer's inspection of the tripod. The manufacturer's inspection can be carried out by: manufacturer or person recommended by manufacturer or company recommended by manufacturer. During this inspection will be established if the tripod can be longer used and will be defined the admissible time of tripod use till next manufacturer's inspection.
- ADMISSIBLE TIME OF USE**
- The tripod can be used for 5 years counting from a date of putting the tripod into operation. After this period the tripod must be withdrawn from use to carry out manufacturer's detailed inspection. The manufacturer inspection can be carried out by: manufacturer or person recommended by manufacturer or company recommended by manufacturer. During this inspection will be established admissible time of period use till next manufacturer's inspection.

PERIODIC EXAMINATION AND REPAIR HISTORY					IDENTITY CARD		
Date of insp.	Type of inspection (periodical/special/...)	Result	Next inspection date	Signature of the person responsible	Device name	Reference number	User name
					Date of manufacture	Serial number	Date of installation
					edition: 4/29.05.2012		